

KSLW-BS

Wall bracket, light, maintenance of function

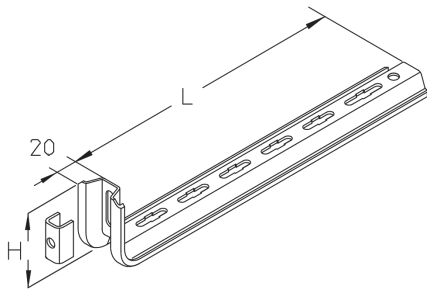

steel, continuously hot galvanized/Sendzimir process

Products	H	B	L	W
KSLW-BS 010S	90 mm	60 mm	170 mm	0,410 kg
KSLW-BS 020S	90 mm	60 mm	270 mm	0,500 kg
KSLW-BS 030S	90 mm	60 mm	370 mm	0,590 kg

steel, batch/hot-dip galvanized

Products	H	B	L	W
KSLW-BS 010F	90 mm	60 mm	170 mm	0,410 kg
KSLW-BS 020F	90 mm	60 mm	270 mm	0,500 kg
KSLW-BS 030F	90 mm	60 mm	370 mm	0,590 kg

H: height

B: width

L: length

W: Weight per storage unit

DETAIL AND APPLICATION IMAGES



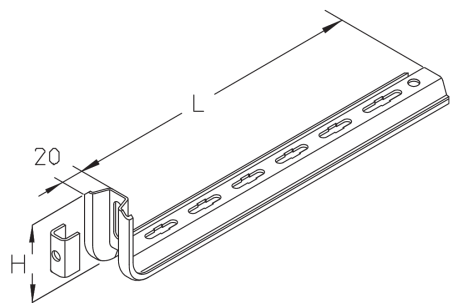

OPTIONAL ACCESSORIES

SAZ, SD, KLRL, GB, VM

