

KHZ

Z profile

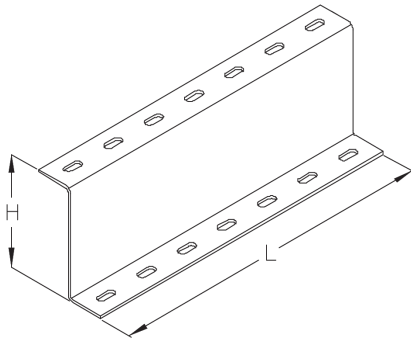

The KHZ floor duct bracket is used to elevate the floor duct if, for example, media lines are to be installed below the floor duct system. It is advisable to space the supports 1.5 m apart. Make sure that they are arranged alternately during assembly. The Z profile is 80, 100 or 120 mm high and is made of sendzimir hot-dip galvanized steel.

steel, continuously hot galvanized/Sendzimir process

Products	H	L	t	W
KHZ 80-01S	80 mm	100 mm	3,00 mm	0,320 kg
KHZ 80-02S	80 mm	200 mm	3,00 mm	0,650 kg
KHZ 80-03S	80 mm	300 mm	3,00 mm	0,980 kg
KHZ 80-04S	80 mm	400 mm	3,00 mm	1,310 kg
KHZ 80-05S	80 mm	500 mm	3,00 mm	1,640 kg
KHZ 80-06S	80 mm	600 mm	3,00 mm	1,970 kg
KHZ 80-30S	80 mm	3000 mm	3,00 mm	9,880 kg
KHZ 100-01S	100 mm	100 mm	3,00 mm	0,370 kg
KHZ 100-02S	100 mm	200 mm	3,00 mm	0,740 kg
KHZ 100-03S	100 mm	300 mm	3,00 mm	1,120 kg
KHZ 100-04S	100 mm	400 mm	3,00 mm	1,490 kg
KHZ 100-05S	100 mm	500 mm	3,00 mm	1,860 kg
KHZ 100-06S	100 mm	600 mm	3,00 mm	2,230 kg
KHZ 100-30S	100 mm	3000 mm	3,00 mm	11,180 kg
KHZ 120-01S	120 mm	3000 mm	3,00 mm	0,440 kg
KHZ 120-02S	120 mm	200 mm	3,00 mm	0,880 kg
KHZ 120-03S	120 mm	300 mm	3,00 mm	1,320 kg
KHZ 120-04S	120 mm	400 mm	3,00 mm	1,760 kg
KHZ 120-05S	120 mm	500 mm	3,00 mm	2,200 kg
KHZ 120-06S	120 mm	600 mm	3,00 mm	2,640 kg
KHZ 120-30S	120 mm	3000 mm	3,00 mm	13,190 kg

Page 1



PRODUCT INFORMATION

H: height
L: length
t: material thickness
W: Weight per storage unit

DETAIL AND APPLICATION IMAGES

