

# PRODUCT INFORMATION

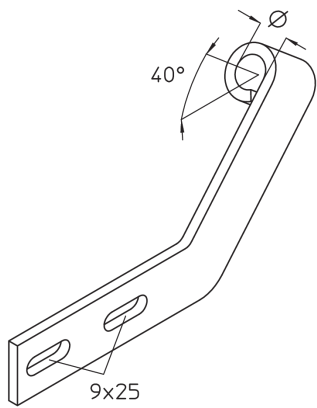

## KAW-BS

Bracket adapter, maintenance of function



steel, continuously hot galvanized/Sendzimir process

Products	∅	W
KAW-BS S	13 mm	0,332 kg
incl.:		
2 × IK 8X20, 2 × SEMS 8		

steel, batch/hot-dip galvanized

Products	∅	W
KAW-BS F	13 mm	0,332 kg
incl.:		
2 × IK 8X20E, 2 × SEMS 8E		

∅: inner diameter

W: Weight per storage unit

## DETAIL AND APPLICATION IMAGES

Page 1



PohlCon GmbH  
Nobelstraße 51 | 12057 Berlin  
Telefon: +49 30 68283-04 | Fax: +49 30 68283-383 | contact@pohlcon.com



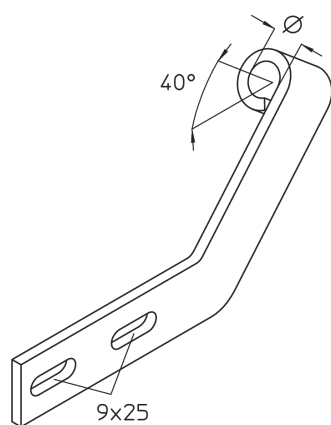

## OPTIONAL ACCESSORIES

W-BS, SAZ, SD, GB, VM

