

HF-EM 8 5-6

HF cable clamps for fastening to walls

The HF cable clamps HF-EM 8 5-6 with hexagon socket head screw IKK 8x10 can be used to route fibre-optic/high-frequency cables with a diameter of max. 160 mm. They are suitable for mounting directly on the wall and are made of galvanised steel. Use HF-EE clamp inserts to accommodate various elliptical cables.

steel, batch/hot-dip galvanized

Products		Cable diameter	W
HF-EM 8 5	E 26-30	128 mm	0,857 kg
HF-EM 8 6	E 20	160 mm	1,077 kg

Cable diameter: Suitable for max. cable diameter

W: Weight per storage unit

DETAIL AND APPLICATION IMAGES

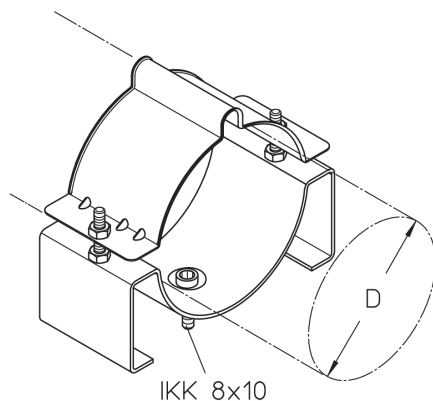

OPTIONAL ACCESSORIES

HF-EE, SA, SAZ, MKD

