

## HF-EL 1-4

HF cable clamps for fastening to walls

The HF cable clamps HF-EL 1-4 can be used to route fibre-optic/high-frequency cables with a maximum diameter of 100 mm. They are suitable for mounting directly on the wall and are made of galvanised steel. Use HF-EE clamp inserts to accommodate various elliptical cables.

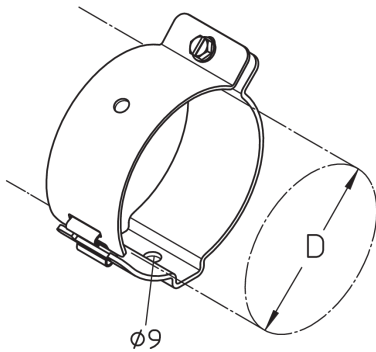

steel, batch/hot-dip galvanized

Products		Cable diameter	W
HF-EL 1	E 130-190	37 mm	0,128 kg
HF-EL 2	E 78-105	50 mm	0,184 kg
HF-EL 3	E 60-70	62 mm	0,220 kg
HF-EL 4	E 38-46	100 mm	0,326 kg

**Cable diameter:** Suitable for max. cable diameter

**W:** Weight per storage unit

## DETAIL AND APPLICATION IMAGES

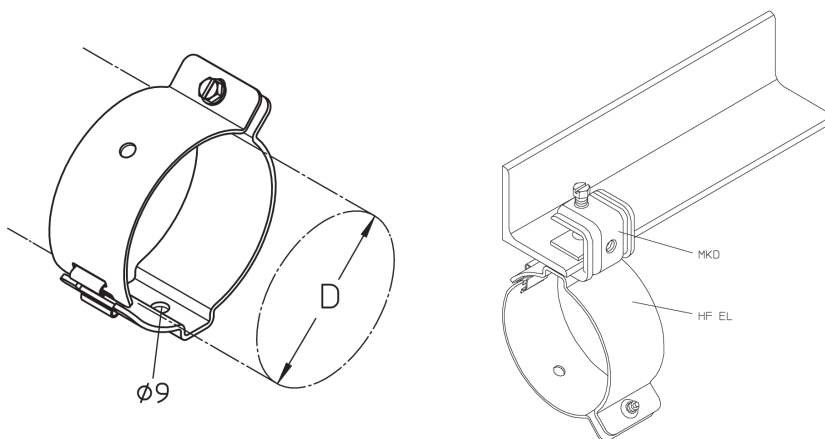

## OPTIONAL ACCESSORIES

HF-EE

