

HB-IW

Cable clamp with additional insulating tray for fastening to C profile rails

The HB-IW cable clamp with a full-surface pressure trough made of galvanised steel and an additional insulating trough made of polystyrene can route cables with a maximum diameter of 70 mm. It is suitable for attachment to C profile rails with a slot width of 11-12 mm. On request, a GW counter trough can be fitted for improved cable support. The HB-IW cable clamp is made of galvanised steel.

steel, zinc plated

Products	D	H _{max}	cables	M	W
12 HB-IW	8 - 12 mm	42,5 mm	1	2 Nm	0,024 kg
16 HB-IW	12 - 16 mm	47,5 mm	1	2 Nm	0,028 kg
20 HB-IW	16 - 20 mm	51,5 mm	1	2 Nm	0,032 kg
24 HB-IW	20 - 24 mm	55,7 mm	1	2 Nm	0,034 kg
28 HB-IW	24 - 28 mm	59,7 mm	1	2 Nm	0,042 kg
32 HB-IW	28 - 32 mm	65 mm	1	2 Nm	0,062 kg
36 HB-IW	32 - 36 mm	69 mm	1	2 Nm	0,064 kg
40 HB-IW	36 - 40 mm	73 mm	1	2 Nm	0,074 kg
44 HB-IW	40 - 44 mm	83 mm	1	4 Nm	0,089 kg
48 HB-IW	44 - 48 mm	87 mm	1	4 Nm	0,097 kg
52 HB-IW	48 - 52 mm	92,5 mm	1	4 Nm	0,106 kg
56 HB-IW	52 - 56 mm	96,5 mm	1	4 Nm	0,119 kg
60 HB-IW	56 - 60 mm	100,5 mm	1	4 Nm	0,143 kg
64 HB-IW	60 - 64 mm	104,5 mm	1	4 Nm	0,155 kg
70 HB-IW	64 - 70 mm	111,5 mm	1	4 Nm	0,170 kg

D: clamping range

H_{max}: maximum height

cables: max. number of cables

M: torque

W: Weight per storage unit



PRODUCT INFORMATION

DETAIL AND APPLICATION IMAGES

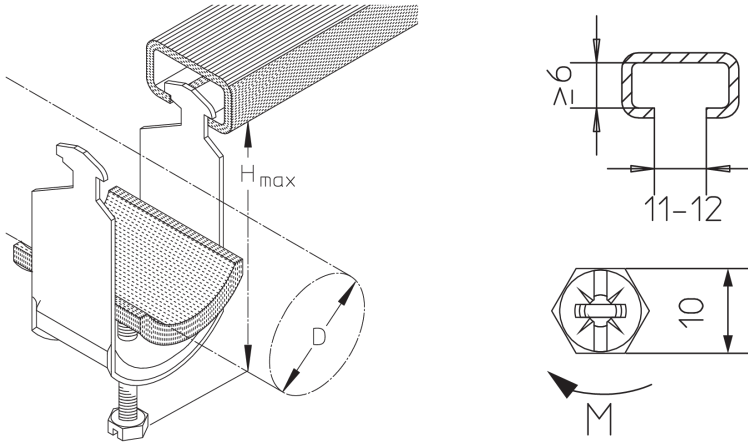

OPTIONAL ACCESSORIES

GW 12-70, B 3, B 6

