

H

Cable clamp for fastening to C profile rails

The H cable clamp with full-surface pressure trough made of galvanised steel can guide cables with a maximum diameter of 70 mm. It is suitable for attachment to C profile rails with a slot width of 16 mm. On request, a GW counter trough can be fitted for improved cable support. We provide components in various materials and surface finishes to ensure that various requirements for different areas of application are met. Articles with a diameter of 12 to 56 mm are also available in stainless steel with material no. 1.4571/1.4404 (V4A).

steel, zinc plated

Products	D	H _{max}	cables	M	W
12 H	8 - 12 mm	41 mm	1	2 Nm	0,025 kg
16 H	12 - 16 mm	46 mm	1	2 Nm	0,029 kg
20 H	16 - 20 mm	50 mm	1	2 Nm	0,033 kg
24 H	20 - 24 mm	54 mm	1	2 Nm	0,036 kg
28 H	24 - 28 mm	58 mm	1	2 Nm	0,040 kg
32 H	28 - 32 mm	63 mm	1	2 Nm	0,059 kg
36 H	32 - 36 mm	67 mm	1	2 Nm	0,065 kg
40 H	36 - 40 mm	71 mm	1	2 Nm	0,072 kg
44 H	40 - 44 mm	81 mm	1	4 Nm	0,086 kg
48 H	44 - 48 mm	85 mm	1	4 Nm	0,095 kg
52 H	48 - 52 mm	90 mm	1	4 Nm	0,105 kg
56 H	52 - 56 mm	94 mm	1	4 Nm	0,109 kg
60 H	56 - 60 mm	98 mm	1	4 Nm	0,146 kg
64 H	60 - 64 mm	102 mm	1	4 Nm	0,154 kg
70 H	64 - 70 mm	109 mm	1	4 Nm	0,170 kg
12/2 H	8 - 12 mm	58 mm	2	2 Nm	0,034 kg
16/2 H	12 - 16 mm	67 mm	2	2 Nm	0,039 kg
20/2 H	16 - 20 mm	75 mm	2	2 Nm	0,045 kg
24/2 H	20 - 24 mm	84 mm	2	2 Nm	0,049 kg
28/2 H	24 - 28 mm	92 mm	2	2 Nm	0,055 kg
32/2 H	28 - 32 mm	101 mm	2	2 Nm	0,084 kg

Page 1



PRODUCT INFORMATION

Products	D	H _{max}	cables	M	W
36/2 H	32 - 36 mm	109 mm	2	2 Nm	0,092 kg
40/2 H	36 - 40 mm	117 mm	2	2 Nm	0,101 kg
44/2 H	40 - 44 mm	127 mm	2	4 Nm	0,120 kg
48/2 H	44 - 48 mm	135 mm	2	4 Nm	0,136 kg
52/2 H	48 - 52 mm	144 mm	2	4 Nm	0,147 kg
56/2 H	52 - 56 mm	152 mm	2	4 Nm	0,154 kg

aluminium

Products	D	H _{max}	cables	M	W
12 H-AL	8 - 12 mm	41 mm	1	1,5 Nm	0,011 kg
16 H-AL	12 - 16 mm	46 mm	1	1,5 Nm	0,014 kg
20 H-AL	16 - 20 mm	50 mm	1	1,5 Nm	0,016 kg
24 H-AL	20 - 24 mm	54 mm	1	1,5 Nm	0,018 kg
28 H-AL	24 - 28 mm	58 mm	1	1,5 Nm	0,021 kg
32 H-AL	28 - 32 mm	63 mm	1	1,5 Nm	0,033 kg
36 H-AL	32 - 36 mm	67 mm	1	1,5 Nm	0,037 kg
40 H-AL	36 - 40 mm	71 mm	1	1,5 Nm	0,041 kg
44 H-AL	40 - 44 mm	81 mm	1	3 Nm	0,045 kg
48 H-AL	44 - 48 mm	85 mm	1	3 Nm	0,049 kg
52 H-AL	48 - 52 mm	90 mm	1	3 Nm	0,053 kg
56 H-AL	52 - 56 mm	94 mm	1	3 Nm	0,057 kg

Stainless steel, according to ASTM 304 / BS 304 S 3

Products	D	H _{max}	cables	M	W
12 H-E	8 - 12 mm	41 mm	1	2 Nm	0,026 kg
16 H-E	12 - 16 mm	46 mm	1	2 Nm	0,029 kg
20 H-E	16 - 20 mm	50 mm	1	2 Nm	0,032 kg
24 H-E	20 - 24 mm	54 mm	1	2 Nm	0,036 kg
28 H-E	24 - 28 mm	58 mm	1	2 Nm	0,039 kg
32 H-E	28 - 32 mm	63 mm	1	2 Nm	0,047 kg



PohlCon GmbH
Nobelstraße 51 | 12057 Berlin
Telefon: +49 30 68283-04 | Fax: +49 30 68283-383 | contact@pohlcon.com



PRODUCT INFORMATION

Products	D	H _{max}	cables	M	W
36 H-E	32 - 36 mm	67 mm	1	2 Nm	0,057 kg
40 H-E	36 - 40 mm	71 mm	1	2 Nm	0,066 kg
44 H-E	40 - 44 mm	81 mm	1	4 Nm	0,079 kg
48 H-E	44 - 48 mm	85 mm	1	4 Nm	0,090 kg
52 H-E	48 - 52 mm	90 mm	1	4 Nm	0,097 kg
56 H-E	52 - 56 mm	94 mm	1	4 Nm	0,107 kg
12/2 H-E	8 - 12 mm	58 mm	2	2 Nm	0,032 kg
16/2 H-E	12 - 16 mm	67 mm	2	2 Nm	0,038 kg
20/2 H-E	16 - 20 mm	75 mm	2	2 Nm	0,043 kg
24/2 H-E	20 - 24 mm	84 mm	2	2 Nm	0,049 kg
28/2 H-E	24 - 28 mm	92 mm	2	2 Nm	0,054 kg
32/2 H-E	28 - 32 mm	101 mm	2	2 Nm	0,068 kg

D: clamping range
H_{max}: maximum height
cables: max. number of cables
M: torque
W: Weight per storage unit

DETAIL AND APPLICATION IMAGES

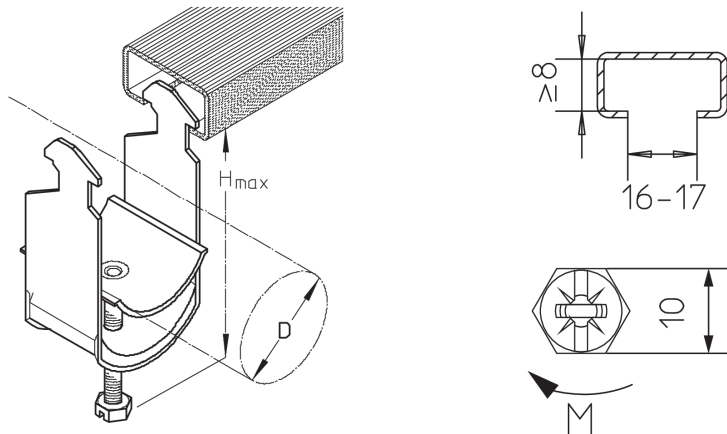

OPTIONAL ACCESSORIES

GW 12-70, GW 76-120, GW 150-175, DW, LW, B 7, KHB 7

Page 3



PohlCon GmbH
 Nobelstraße 51 | 12057 Berlin
 Telefon: +49 30 68283-04 | Fax: +49 30 68283-383 | contact@pohlcon.com





PohlCon GmbH
Nobelstraße 51 | 12057 Berlin
Telefon: +49 30 68283-04 | Fax: +49 30 68283-383 | contact@pohlcon.com

