

BKTE 100

Floor duct telescopic insert, height = 100 mm

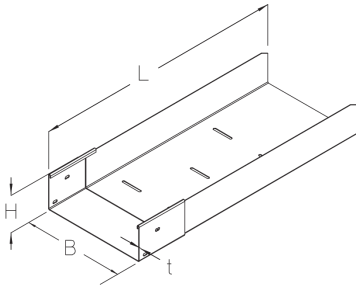

The floor duct telescopic insert BKTE 100 ensures full flexibility during assembly. Its length can be continuously adjusted between 150 and 650 mm allowing two floor ducts to be variably connected without requiring any cutting work. The telescopic insert is pushed into the existing channel by at least 50 mm on one side. The perforated side of the telescopic insert can be bolted together with the BKV connectors. Subsequent changes can be made to the system with very little effort. The floor duct telescopic insert is available in sendzimir hot-dip galvanised steel. The sides are 100 mm high and it is 100 to 600 mm wide. The total length is 700 mm.

steel, continously hot galvanized/Sendzimir process

Products	H	B	L	t	weight
BKTE 100-700-10S	100 mm	100 mm	700 mm	1,50 mm	2,620 kg
BKTE 100-700-15S	100 mm	150 mm	700 mm	1,50 mm	3,080 kg
BKTE 100-700-20S	100 mm	200 mm	700 mm	1,50 mm	3,520 kg
BKTE 100-700-30S	100 mm	300 mm	700 mm	1,50 mm	4,460 kg
BKTE 100-700-40S	100 mm	400 mm	700 mm	1,50 mm	5,370 kg
BKTE 100-700-50S	100 mm	500 mm	700 mm	1,50 mm	6,280 kg
BKTE 100-700-60S	100 mm	600 mm	700 mm	1,50 mm	7,190 kg

H: height
B: width
L: length
t: material thickness

DETAIL AND APPLICATION IMAGES



PRODUCT INFORMATION

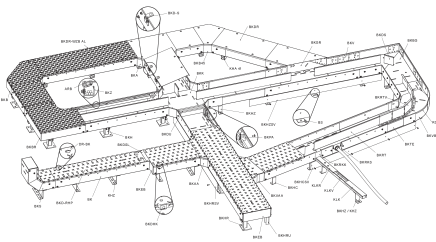
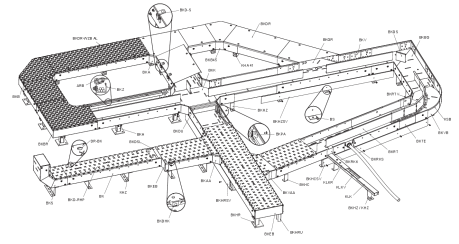
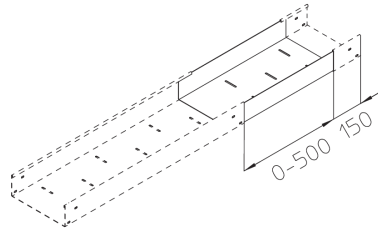
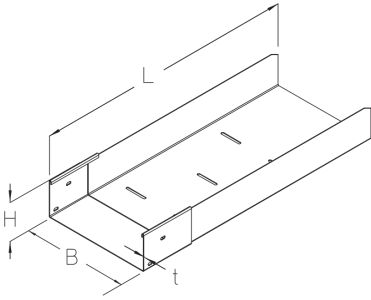

OPTIONAL ACCESSORIES

BKDR, BKD-RHP, BKDR-WZB AL, BKV 100, BKRT 100, BKRTV 100, BKEB 100

