

## BKH

Floor duct holder, height = 110 mm

The BKH floor duct bracket with C rail is used to elevate the floor duct, e.g. if media lines are to be installed below the floor duct system. It is advisable to space the supports 1.5 m apart. Floor duct brackets can be used for additional routing of cables underneath the structure using cable clamps. The cable clamps are selected to match the C profile and the cables being installed. The floor duct bracket BKH is 110 mm high, 100, 200 or 300 mm long and is made of hot-dip galvanised steel.

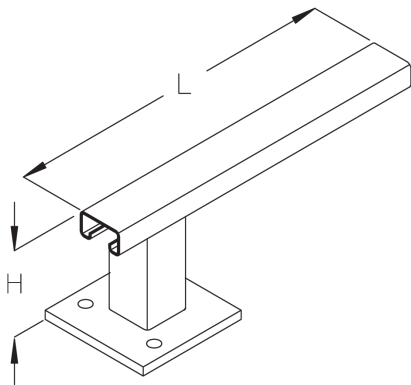

steel, batch/hot-dip galvanized

Products	H	L	W
BKH 10F	110 mm	100 mm	0,880 kg
BKH 20F	110 mm	200 mm	1,050 kg
BKH 30F	110 mm	300 mm	1,210 kg

**H:** height  
**L:** length  
**W:** Weight per storage unit

## DETAIL AND APPLICATION IMAGES

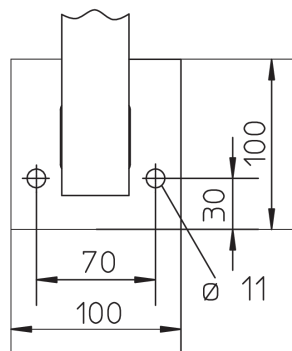
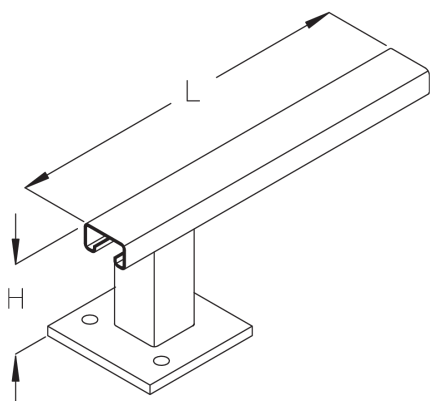

## OPTIONAL ACCESSORIES

AC

