

BKB45 100

Floor duct bend 45°, height = 100 mm

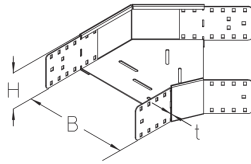

The floor duct bend BKB45 100 with integrated connectors allows the direction of cable routing to be changed horizontally by 45°. It is 100 mm high and 100 to 600 mm wide. It is made of sendzimir hot-dip galvanized steel. To dissipate vertical live loads, one separating strip must be installed in the floor duct for widths ≥ 300 mm and two separating strips for widths ≥ 500 mm. The bend is pushed into the floor ducts and then bolted in place.

steel, continuously hot galvanized/Sendzimir process

Products	H	B	t			weight
BKB45 100-10S	100 mm	100 mm	2,00 mm	45 °	HORIZONTAL	1,700 kg
incl.:						
4 × KLR						
BKB45 100-15S	100 mm	150 mm	2,00 mm	45 °	HORIZONTAL	1,940 kg
incl.:						
4 × KLR						
BKB45 100-20S	100 mm	200 mm	2,00 mm	45 °	HORIZONTAL	2,200 kg
incl.:						
4 × KLR						
BKB45 100-30S	100 mm	300 mm	2,00 mm	45 °	HORIZONTAL	2,820 kg
incl.:						
4 × KLR						
BKB45 100-40S	100 mm	400 mm	2,00 mm	45 °	HORIZONTAL	3,590 kg
incl.:						
4 × KLR						
BKB45 100-50S	100 mm	500 mm	2,00 mm	45 °	HORIZONTAL	4,470 kg
incl.:						
4 × KLR						
BKB45 100-60S	100 mm	600 mm	2,00 mm	45 °	HORIZONTAL	5,486 kg
incl.:						
4 × KLR						

Page 1



PRODUCT INFORMATION

H: height
B: width
t: material thickness

DETAIL AND APPLICATION IMAGES

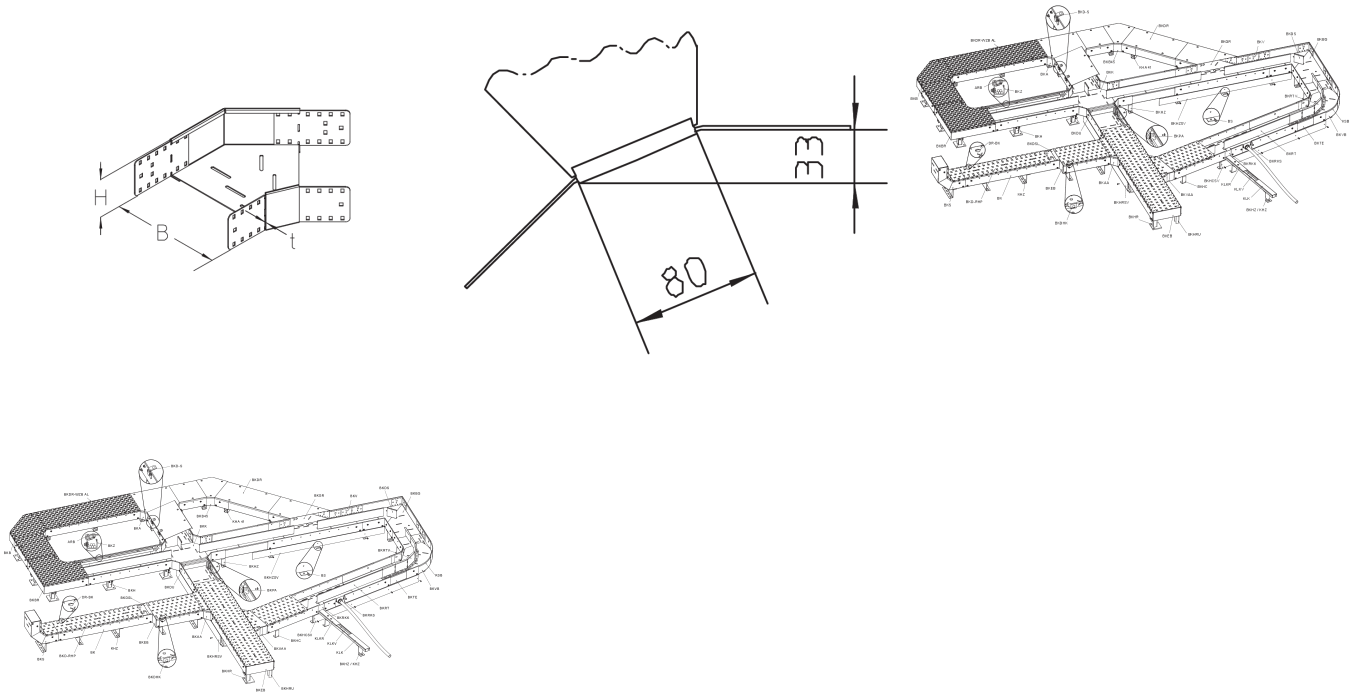

OPTIONAL ACCESSORIES

BKBDR45, BKBDR45-RHP, BKBDR45-WZB AL, BKRTV 100, BKDS 100

