

BGUQ 50

Bolted head plate turned 90°, STU 50

The head plate BGUQ 50 with a plate turned at right angles to the rail is used to attach the STU 50 vertical ladders to the ceiling and/or floor. We provide components in various materials and surface finishes to ensure that the corrosion requirements are met for all sorts of applications.

steel, batch/hot-dip galvanized

Products	H	B	L	weight
BGUQ 50F	156 mm	80 mm	150 mm	0,993 kg
incl.:				
2 × SEM 10F, 2 × US 10X21F, 2 × FRSV 10X20F				

Stainless steel, according to ASTM 304 / BS 304 S 3

Products	H	B	L	weight
BGUQ 50E	156 mm	80 mm	150 mm	0,939 kg
incl.:				
2 × SEM 10E, 2 × US 10X21E, 2 × FRSV 10X20E				

H: height
B: width
L: length

DETAIL AND APPLICATION IMAGES



PRODUCT INFORMATION

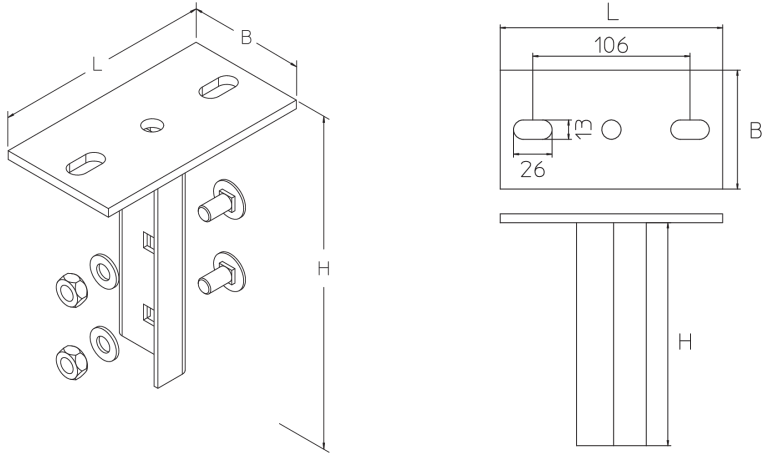

OPTIONAL ACCESSORIES

SD

