

B-IW

Cable clamp with additional insulating tray for fastening to C profile rails

The B-IW cable clamp with full-surface pressure trough can guide cables with a maximum diameter of 70 mm. It is suitable for fastening to C-profile rails with a slot width of 11-12 mm. The GW counter trough can be fitted on request for improved cable support.

The article is also available with lock nuts. This prevents unintentional loosening of the clamp. Lock nuts must be specified separately when ordering.

The B-IW cable clamp is made of galvanized steel.

steel, zinc plated

Products	H _{max}	D	M	cables	W
12 B-IW	42,5 mm	8 - 12 mm	2 Nm	1	0,024 kg
16 B-IW	47,5 mm	12 - 16 mm	2 Nm	1	0,028 kg
20 B-IW	51,5 mm	16 - 20 mm	2 Nm	1	0,033 kg
24 B-IW	55,7 mm	20 - 24 mm	2 Nm	1	0,036 kg
28 B-IW	59,7 mm	24 - 28 mm	2 Nm	1	0,041 kg
32 B-IW	65 mm	28 - 32 mm	2 Nm	1	0,051 kg
36 B-IW	69 mm	32 - 36 mm	2 Nm	1	0,056 kg
40 B-IW	73 mm	36 - 40 mm	2 Nm	1	0,061 kg
44 B-IW	83 mm	40 - 44 mm	4 Nm	1	0,085 kg
48 B-IW	87 mm	44 - 48 mm	4 Nm	1	0,087 kg
52 B-IW	92,5 mm	48 - 52 mm	4 Nm	1	0,092 kg
56 B-IW	96,5 mm	52 - 56 mm	4 Nm	1	0,101 kg
60 B-IW	100,5 mm	56 - 60 mm	4 Nm	1	0,135 kg
64 B-IW	104,5 mm	60 - 64 mm	4 Nm	1	0,144 kg
70 B-IW	111,5 mm	64 - 70 mm	4 Nm	1	0,153 kg

H_{max}: maximum height

D: clamping range

M: torque

cables: max. number of cables

W: Weight per storage unit



PRODUCT INFORMATION

DETAIL AND APPLICATION IMAGES

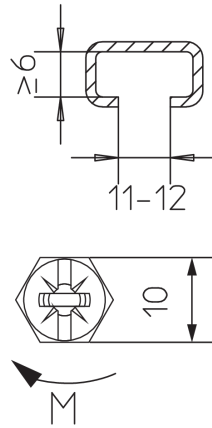
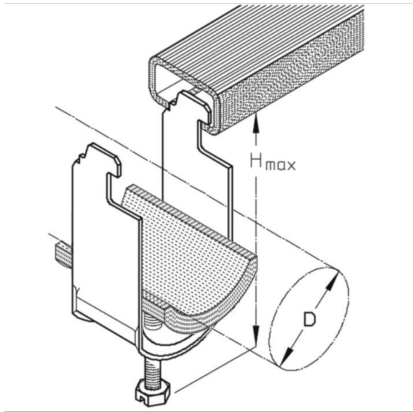

OPTIONAL ACCESSORIES

GW 12-70, DW, B 3, B 6

