

PRODUCT INFORMATION

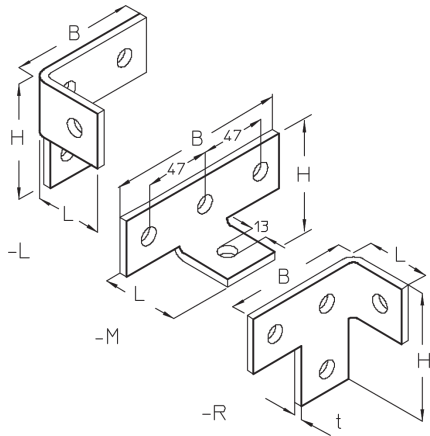

AVAW

Rail connector bracket

The channel connector bracket AVAW can be used to connect mounting channels together as crossings or branches. The channel connector brackets consist of a T branch angled to the left, centre or right. They are made of hot-dip galvanised steel.

steel, batch/hot-dip galvanized

Products	H	B	L	t		weight
AVAW-L F	90 mm	98 mm	48 mm	6,00 mm	90 °	0,360 kg
AVAW-M F	50 mm	136 mm	51 mm	6,00 mm	90 °	0,360 kg
AVAW-R F	90 mm	98 mm	48 mm	6,00 mm	90 °	0,360 kg

H: height
B: width
L: length
t: material thickness

DETAIL AND APPLICATION IMAGES

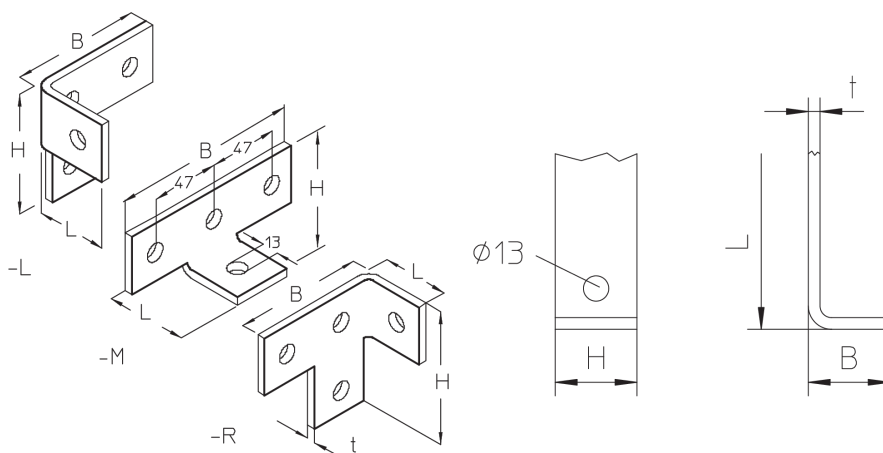

Page 1



OPTIONAL ACCESSORIES

SES, AM 22, AMF 22

