

AC

Cable clamp for fastening to C profile rails

The AC cable clamp with full-surface pressure trough made of galvanised steel can guide cables with a maximum diameter of 175 mm. It is suitable for attachment to profile rails C+ and C60° with a slot width of 18/22 mm. On request, a GW counter trough can be fitted for improved cable support. We provide components in various materials and surface finishes to ensure that various requirements for different areas of application are met.

In conjunction with a grub screw that penetrates the coating, the cable clamp can be included in the equipotential bonding. The article is also available with lock nuts. This prevents the clamp from unintentionally coming loose. Grub screw and lock nuts must be specified separately when ordering.

Articles with a diameter of 12 to 56 mm are also available in aluminium or stainless steel with material no. 1.4571/1.4404 (V4A).

steel, zinc plated

Products	D	H _{max}	cables	M	W
12 AC	8 - 12 mm	41 mm	1	2 Nm	0,024 kg
16 AC	12 - 16 mm	46 mm	1	2 Nm	0,028 kg
20 AC	16 - 20 mm	50 mm	1	2 Nm	0,031 kg
24 AC	20 - 24 mm	54 mm	1	2 Nm	0,036 kg
28 AC	24 - 28 mm	58 mm	1	2 Nm	0,039 kg
32 AC	28 - 32 mm	63 mm	1	2 Nm	0,061 kg
36 AC	32 - 36 mm	67 mm	1	2 Nm	0,064 kg
40 AC	36 - 40 mm	71 mm	1	2 Nm	0,071 kg
44 AC	40 - 44 mm	81 mm	1	4 Nm	0,091 kg
48 AC	44 - 48 mm	85 mm	1	4 Nm	0,091 kg
52 AC	48 - 52 mm	90 mm	1	4 Nm	0,104 kg
56 AC	52 - 56 mm	94 mm	1	4 Nm	0,109 kg
60 AC	56 - 60 mm	98 mm	1	4 Nm	0,141 kg
64 AC	60 - 64 mm	102 mm	1	4 Nm	0,147 kg
70 AC	64 - 70 mm	109 mm	1	4 Nm	0,159 kg
76 AC	70 - 76 mm	113 mm	1	4 Nm	0,221 kg
82 AC	76 - 82 mm	119 mm	1	4 Nm	0,234 kg

Page 1



PRODUCT INFORMATION

Products	D	H _{max}	cables	M	W
88 AC	82 - 88 mm	125 mm	1	4 Nm	0,252 kg
94 AC	88 - 94 mm	131 mm	1	4 Nm	0,279 kg
100 AC	94 - 100 mm	137 mm	1	4 Nm	0,292 kg
110 AC	101 - 110 mm	157 mm	1	4 Nm	0,313 kg
120 AC	111 - 120 mm	167 mm	1	4 Nm	0,333 kg
150 AC	145 - 150 mm	203 mm	1	6 Nm	1,046 kg
175 AC	170 - 175 mm	228 mm	1	6 Nm	1,303 kg
12/2 AC	8 - 12 mm	58 mm	2	2 Nm	0,032 kg
16/2 AC	12 - 16 mm	67 mm	2	2 Nm	0,037 kg
20/2 AC	16 - 20 mm	75 mm	2	2 Nm	0,044 kg
24/2 AC	20 - 24 mm	84 mm	2	2 Nm	0,049 kg
28/2 AC	24 - 28 mm	92 mm	2	2 Nm	0,056 kg
32/2 AC	28 - 32 mm	101 mm	2	2 Nm	0,086 kg
36/2 AC	32 - 36 mm	109 mm	2	2 Nm	0,091 kg
40/2 AC	36 - 40 mm	117 mm	2	2 Nm	0,106 kg
44/2 AC	40 - 44 mm	127 mm	2	4 Nm	0,135 kg
48/2 AC	44 - 48 mm	135 mm	2	4 Nm	0,132 kg
52/2 AC	48 - 52 mm	144 mm	2	4 Nm	0,142 kg
56/2 AC	52 - 56 mm	152 mm	2	4 Nm	0,153 kg
12/3 AC	8 - 12 mm	71 mm	3	2 Nm	0,039 kg
16/3 AC	12 - 16 mm	85 mm	3	2 Nm	0,046 kg
20/3 AC	16 - 20 mm	97 mm	3	2 Nm	0,054 kg
24/3 AC	20 - 24 mm	110 mm	3	2 Nm	0,061 kg
28/3 AC	24 - 28 mm	122 mm	3	2 Nm	0,073 kg

aluminium

Products	D	H _{max}	cables	M	W
12 AC-AL	8 - 12 mm	41 mm	1	1,5 Nm	0,011 kg
16 AC-AL	12 - 16 mm	46 mm	1	1,5 Nm	0,013 kg
20 AC-AL	16 - 20 mm	50 mm	1	1,5 Nm	0,015 kg
24 AC-AL	20 - 24 mm	54 mm	1	1,5 Nm	0,017 kg
28 AC-AL	24 - 28 mm	58 mm	1	1,5 Nm	0,020 kg

Page 2



PohlCon GmbH
 Nobelstraße 51 | 12057 Berlin
 Telefon: +49 30 68283-04 | Fax: +49 30 68283-383 | contact@pohlcon.com



PRODUCT INFORMATION

Products	D	H _{max}	cables	M	W
32 AC-AL	28 - 32 mm	63 mm	1	1,5 Nm	0,033 kg
36 AC-AL	32 - 36 mm	67 mm	1	1,5 Nm	0,035 kg
40 AC-AL	36 - 40 mm	71 mm	1	1,5 Nm	0,040 kg
44 AC-AL	40 - 44 mm	81 mm	1	3 Nm	0,044 kg
48 AC-AL	44 - 48 mm	85 mm	1	3 Nm	0,047 kg
52 AC-AL	48 - 52 mm	90 mm	1	3 Nm	0,051 kg
56 AC-AL	52 - 56 mm	94 mm	1	3 Nm	0,055 kg

Stainless steel, according to ASTM 304 / BS 304 S 3

Products	D	H _{max}	cables	M	W
12 AC-E	8 - 12 mm	41 mm	1	2 Nm	0,023 kg
16 AC-E	12 - 16 mm	46 mm	1	2 Nm	0,026 kg
20 AC-E	16 - 20 mm	50 mm	1	2 Nm	0,030 kg
24 AC-E	20 - 24 mm	54 mm	1	2 Nm	0,033 kg
28 AC-E	24 - 28 mm	58 mm	1	2 Nm	0,037 kg
32 AC-E	28 - 32 mm	63 mm	1	2 Nm	0,051 kg
36 AC-E	32 - 36 mm	67 mm	1	2 Nm	0,055 kg
40 AC-E	36 - 40 mm	71 mm	1	2 Nm	0,060 kg
44 AC-E	40 - 44 mm	81 mm	1	4 Nm	0,078 kg
48 AC-E	44 - 48 mm	85 mm	1	4 Nm	0,085 kg
52 AC-E	48 - 52 mm	90 mm	1	4 Nm	0,092 kg
56 AC-E	52 - 56 mm	94 mm	1	4 Nm	0,095 kg
12/2 AC-E	8 - 12 mm	58 mm	2	2 Nm	0,030 kg
16/2 AC-E	12 - 16 mm	67 mm	2	2 Nm	0,036 kg
20/2 AC-E	16 - 20 mm	75 mm	2	2 Nm	0,041 kg
24/2 AC-E	20 - 24 mm	84 mm	2	2 Nm	0,046 kg
28/2 AC-E	24 - 28 mm	92 mm	2	2 Nm	0,051 kg
32/2 AC-E	28 - 32 mm	101 mm	2	2 Nm	0,072 kg
36/2 AC-E	32 - 36 mm	109 mm	2	2 Nm	0,077 kg
40/2 AC-E	36 - 40 mm	117 mm	2	2 Nm	0,087 kg
44/2 AC-E	40 - 44 mm	127 mm	2	4 Nm	0,117 kg
48/2 AC-E	44 - 48 mm	135 mm	2	4 Nm	0,143 kg



PohlCon GmbH
 Nobelstraße 51 | 12057 Berlin
 Telefon: +49 30 68283-04 | Fax: +49 30 68283-383 | contact@pohlcon.com



PRODUCT INFORMATION

Products	D	H _{max}	cables	M	W
52/2 AC-E	48 - 52 mm	144 mm	2	4 Nm	0,126 kg
56/2 AC-E	52 - 56 mm	152 mm	2	4 Nm	0,138 kg

D: clamping range
H_{max}: maximum height
cables: max. number of cables
M: torque
W: Weight per storage unit

DETAIL AND APPLICATION IMAGES

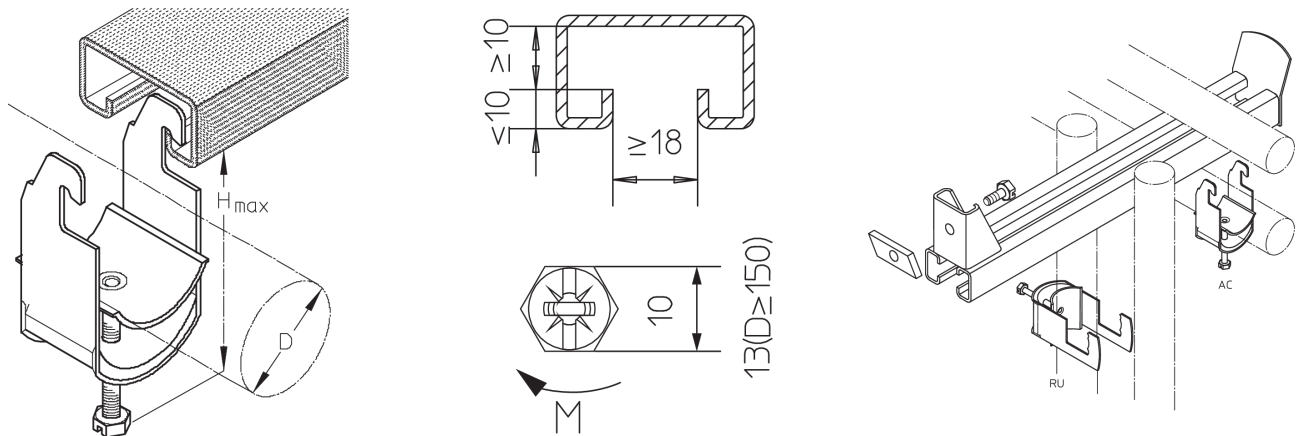

OPTIONAL ACCESSORIES

GW 12-70, GW 76-120, GW 150-175, DW, LW, A 2, A 4, A 7, A 8, A 9, A 41, KHA 21, KHA 41, KHA 42, KHA 82

